

The GSM Approach in Home Security

ALAUSA DELE W.S¹, KESHINRO KAZEEM KOLAWOLE²

¹ SCHOOL OF ENGINEERING, THE FEDERAL POLYTECHNIC, ILARO

² SCHOOL OF ENGINEERING, LAGOS STATE POLYTECHNIC, IKORODU

Abstract: Home security has been a major national issue as crimes remain rampant in our society and it is now becoming uncontrollable. In the past all measures used seems not to be very effective, therefore, people want to take preventive measures to curb this menace and protect their homes by using modern day technology. This system is GSM based which uses wireless technology to revolutionize the security system and standard of living. This paper therefore, focuses on the home security vis-à-vis controlling the home appliances remotely while the owner is away.

This system provides ideal solution to the problems faced by home owners in daily life. Since it is a wireless device, it is therefore more adaptable and cost effective.

Keywords: remote, control, Commands, microcontroller, sensor and Automation.

1. INTRODUCTION

This paper is aimed at developing the security of home against intruders and fire while user is out of home, then the device sends a message to the emergency number provided to it.

The aim of this paper is to investigate a cost effective solution that will provide controlling of home appliances remotely and safely.

There are so many alarm systems emerging in our local markets using high-tech techniques, but in our design we are implementing a home security system using GSM which is one of the latest mobile technologies using smart modems which can be interfaced with microcontrollers. Therefore this paper proposes a system that allows user to control home appliances ubiquitously and also provide security on detection of intrusion using GSM technology.

Home security is a sub-field of home automation which refers to the use of computer and information technology to control home appliances in providing security to various owners.

These Systems can range from simple remote control of appliances through to complex computer/micro-controller based networks with varying degrees of intelligence and automation. Home automated security is adopted for reasons of ease, security and energy efficiency. Home automation can also provide a remote interface to home appliances or the automation system itself, via telephone line, wireless transmission or the internet, to provide control and monitoring via a mobile phone or web browser.

Home automated security has been a feature of science fiction writing for many years, but has only become practical since the early 20th Century following the widespread introduction of electricity into the home, and the rapid advancement of information technology. Early remote control devices began to emerge in the late 1800s.

The emergence of electrical home appliances began between 1915 and 1920; the decline in domestic servants as security men meant that households needed cheap, mechanical replacements. Domestic electricity supply, however, was still in its infancy - meaning this luxury was afforded only the more affluent households

In 1966 Jim Sutherland, an engineer working for Westinghouse Electric, developed a home automation system called "ECHO IV"; this was a private project and never commercialized. The first "wired homes" were built by American hobbyists during the 1960s, but were limited by the technology of the times. The term "smart house" was first coined by the American Association of House builders in 1984.

With the invention of the microcontroller, the cost of electronic control fell rapidly. Remote and intelligent control technologies were adopted by the building services industry and appliance manufacturers worldwide, as they offer the end user easily accessible and/or greater control of their products.

Delgado, Picking, and Grout (2006) consider the problems with the implementation of home automation systems. Furthermore the possible solutions are devised through various network technologies. Several issues affecting home automation systems such as lack of robustness, compatibility issue and acceptability among the old and disabled people are discussed.

Ciubotaru-Petrescu, Chiciudean, Cioarga, and Stanescu (2006) present a design and implementation of SMS based control for monitoring systems. The paper has three modules involving sensing unit for monitoring the complex applications, processing unit that is microcontroller and a communication module that uses GPRS modem or cell phone via serial port RS-232. The SMS is used for status reporting such as power failure.

In their work, Alkar and Buhur (2005) proposed an Internet Based Wireless Home Automation System for Multifunctional Devices that is low cost and flexible web-based but with some limitations such as the range and power failure. While Murthy (2008) explores primary health-care management for the rural population. A solution that proposes the use of the mobile web-technologies providing the PHC services to the rural population. The system involves the use of SMS and cell phone technology for information management, transactional exchange and personal communication.

Jawarkar, Ahmed, Ladhake, and Thakare (2008) proposes remote monitoring through mobile phone involving the use of spoken commands. The spoken commands are generated and sent in the form of text SMS to the control system and then the microcontroller on the basis of SMS takes a decision of a particular task. But Potamitis, Georgila, Fakotakis, and Kokkinakis, G. (2003) suggested in their work the use of speech to interact remotely with the home appliances to perform a particular action on behalf of the user. The approach is inclined for people with disability to perform real-life operations at home by directing appliances through speech. Voice separation strategy is selected to take appropriate decision by speech recognition.

2. DIFFERENT TYPES OF HOME SECURITY DEVICES

There have been many products in the market which helps in providing securities for home; these have used different procedures which are highlighted below:

2.1 CCTV (closed circuit television) in Home Security:

It is the use of video cameras to transmit a signal to a specific place, on a limited set of monitors. It differs from broadcast television in that the signal is not openly transmitted, though it may employ point to point, point to multi-point or mesh wireless links. Although almost all video cameras fit this definition, the term is most applied to those used for surveillance in areas that may need monitoring especially homes. Its main disadvantage is that it is not cost effective and acceptable among the old and disable

2.2 X10 in Home Security:

This is an international and open industry standard for communication among electronic devices which can be used for home security. It primarily uses power line wiring for signaling and control, where the signal involve brief radio frequency bursts representing digital information. X10 was developed in 1975 by pico electronics of Glenrothes, Scotland, in other to allow remote control of home devices and appliances. It remains popular in the home environment with millions of units worldwide, and inexpensive availability of new components. Its limitations is that it cannot work with low power devices such as fluorescent bulbs and attenuation of signals.

2.3 Burglar Alarm in Home Security:

A burglar alarm is a system designed to detect intrusion, unauthorized entry into a building or area. Some burglar alarm systems serves a single purpose of burglary protection, combination system provide both fire and intrusion protection. Intrusion alarm systems may also be combined with closed –circuit television surveillance systems to automatically record the activities of intruders and may interface to access control systems for electrically locked doors.

2.4 GSM in Home Security:

GSM is a short form for global system for mobile communication; it is a cellular technology with an open channel that is used for transmitting voice and data to places around the world. It is also the most popular and wide spread signal for cell phone transmission been used today. Billions of people rely on this signal to provide crisp clear phone calls through their mobile phone. GSM technology is also used for sending and receiving signals from a wireless home security system in the event of an emergency

A large amount of motion sensors and portable home security systems now use cellular technology for remote communication. A GSM enabled security functions just like a mobile phone; it even has its own internal subscriber identity module (SIM) card. This allows the system to dial out and send data to multiple phone numbers when a security breach is detected the system notifies the mobile phones which are connected to it in just few seconds.

The benefit of using GSM are numerous, unlike other wireless technology, the technology provides low-cost high quality digital data transmission. Therefore, the following are used in its implementation: PIC Microcontroller, Power Supply, GSM phone, Gas Unit and Alarm Unit.

3. METHODOLOGY

This device is capable of monitoring a burglar intrusion and gas leakage in the home where it is installed and automatically sends a text message to a specific number indicating the event that occurred (i.e. gas leakage or burglar intrusion), it can be powered by an Ac source or a Dc rechargeable battery. The device gas monitoring section is made up of a GH- 312 gas sensor which is capable of detecting some specific gases including smoke. Gas leakage can be monitored in the surrounding where necessary or in a remote area like the kitchen or car park. In the case of burglar intrusion, an infra red transmitter is installed directly opposite the receiver, and then the receiver section is connected to the Analogue to digital converter section of the Microcontroller to monitor the varying voltage. This device also has a Display unit that displays the output of the device's operation.

The device consists of the various units viz;

- Power supply unit
- Gas monitor
- Burglar detector
- Microcontroller unit
- GSM unit
- Display

3.1 Gas Monitor:

This unit consist of a gas sensor which can sense over five gases namely; Butane, Carbon mono oxide, Methane etc. It also has the capability of sensing smoke. The popular GH-312 Ardiuno gas sensor is used due to its low operating voltage (9-25v) and its portability. The gas sensor sends out 5volts from its output pin on detection of a gas, as such a program is written to test the

pin where the gas sensor's output is connected, whenever the output pin of the gas sensor is 5volts this indicates the presence of gas leakage.

3.2 Buglar Detector:

3.2.1 Transmitter Section:

The transmitter section is made of a 555 timer oscilator to generate a signal of 38khz which is then beamed through an infrared led. The transmitter is positioned opposite the receiver, such that when an intruder/image moves in front of the transmitter, IR ray is prevented from reaching the receiver, this will cause a voltage increase from 0volts to about 2volts in the output voltage of the receiver, as such the Microcontroller will be alerted that there is a presence of unauthorized

intrusion. With the aid of the program embedded in the microcontroller, a text message will be sent through the GSM phone connected to the device.

3.2.2 Receiver Section:

This section consist of the Infrared receiver module whose output is connected to the ADC port of the microcontroller, when an IR red is beam from the transmitter to the surface of the receiver, the output from the receiver is 0volts but when there is no presence of IR ray on the surface, its output voltage is between 2volts to 4.6volts. Such that when an infra red ray reflects on the receiver, its output voltage drops thereby causing an ouput of 5volts from the comparator. The output from the comparator biase a transistor which inturn switches ground to the Alarm section.

3.3 Microcontroller Unit:

This unit monitors the two sensors on the network at about a second interval with great speed and accuracy. The MCU implored is the PIC 16f873 Microcontroller due to its ADC features that allows analogue readings to be converted to digital values. This unit reads the output from the gas sensor and the burglar detector unit. Whenever either or both of the two input units sends an alarming signal to this unit, with the help of a well writing program the MCU sends a saved message to the GSM phone using a set strings called the AT command, when the phone receives this strings from the MCU, it sends the message to the recipient's number as specified by the MCU. When there is a gas/smoke detection the MCU sends "GAS LEAKAGE DETECTED" When there is an unauthorized intrusion the MCU sends "INTRUDER FOUND".

Also as the messages are sent to the GSM the MCU simultaneously outputs the operation on the LCD display.

The MCU communicates the input sections (i.e. gas detector and burglar monitor) through its ADC inputs AN0 and AN1, while it outputs (LCD, and GSM phone) with port B and port C respectively. The Transmit pin (Tx) of the Microcontroller is connected to the receiver (Rx) of the GSM phone, while the Rx pin of the MCU is connected to the Tx pin of the phone. A 4mhz crystal is used in determining the frequency of the microcontroller and two 22p stability capacitor. The operating period of the device is 1micro seconds.

3.4 GSM Unit:

This unit is made of a Sony Ericsson GSM phone interfaced to the microcontroller with a communication cable. This phone was selected due to its support for AT (Attention) command. The source code programmed in the Microcontroller consist of a set of AT command used to instruct the phone to send a predetermined message to a phone number or push a call to notify the user of a security threat where the device is installed.

3.4.1 AT Command:

AT commands are instructions used to control a modem. AT is the abbreviation of Attention. Every command line starts with "AT" or "at". That's why modem commands are called AT commands. Many of the commands that are used to control wired dial-up modems. (See appendices)

The starting "AT" is the prefix that informs the modem about the start of a command line. It is not part of the AT command name. For example, D is the actual AT command name in ATD and +CMGS is the actual AT command name in AT+CMGS. However, some books and web sites use them interchangeably as the name of an AT command.

Here are two types of AT commands:

Basic commands and extended commands:

Basic commands are AT commands that do not start with "+". For example, D (Dial), A (Answer), H (Hook control) and O (Return to online data state) are basic commands.

Extended commands are AT commands that start with "+". All GSM AT commands are extended commands. For example, +CMGS (Send SMS message), +CMSS (Send SMS message from storage), +CMGL (List SMS messages) and +CMGR (Read SMS messages) are extended commands.

3.5 Display Unit:

This unit is made up of 16x2 LCD display unit, this device is added for easy monitoring of the operation of the device.

A liquid crystal display (LCD) is a thin, flat display device made up of any number of Colors or monochrome pixels arrayed in front of a light source or reflector. It is often utilized in battery-powered electronic devices because it uses very small amounts of electric power. This unit displays the operation being carried out by the monitoring device at every point in time. The device is built around a micro-controller unit (PIC 16F873A) because the micro-controller unit has the ADC feature and the USART function for wired and wireless transmission.

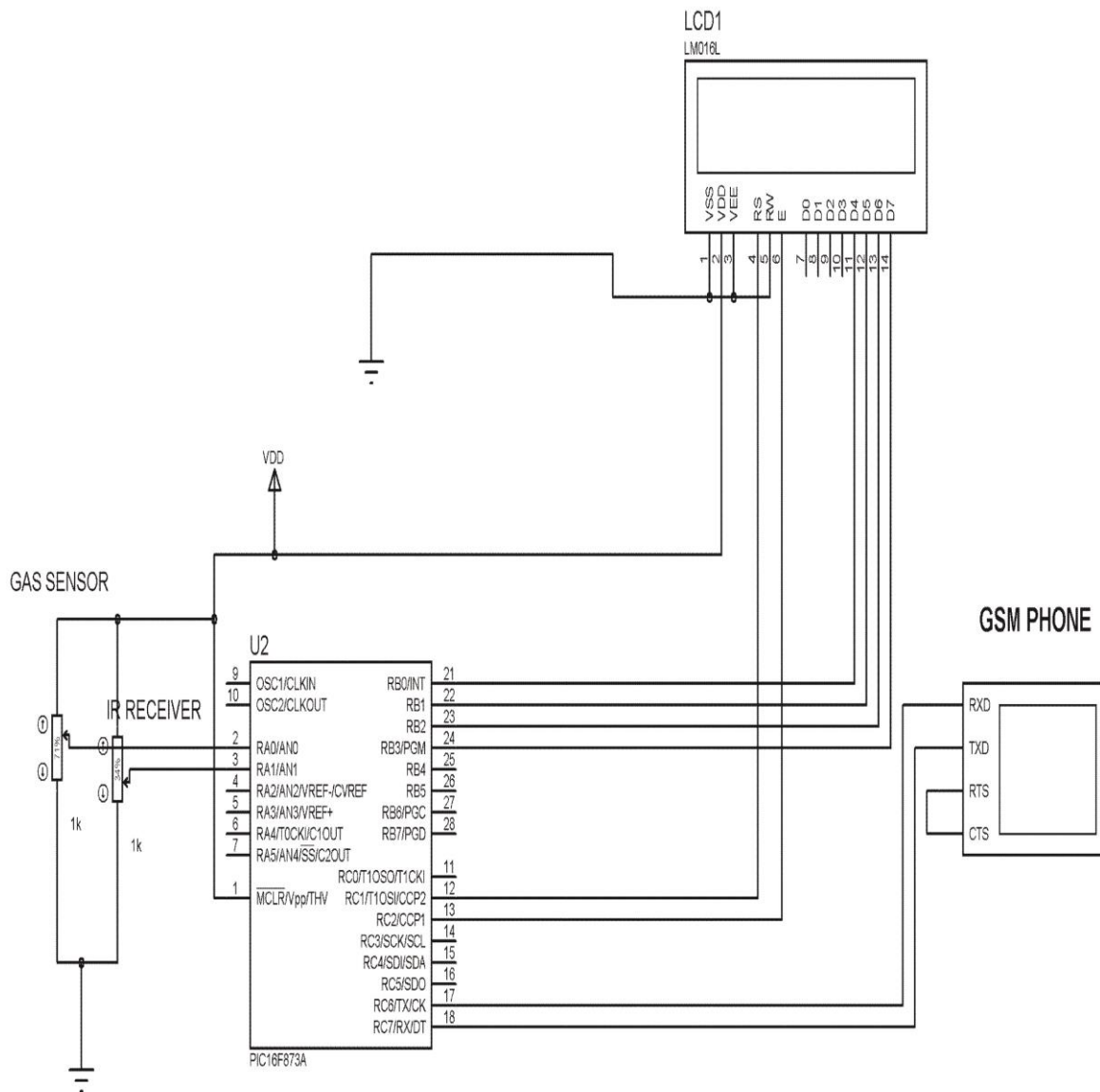

Fig1.0: Schematic diagram of home security simulation

A program is written to monitor pin where a gas sensor and IR receiver is connected.

The gas sensor sends out an output voltage of 5 voltage on detection of gas, and 0 voltage when no gas is present.

Also an Infra-red ray is being emitted from the IR transmitter with the aid of an oscillator. IR sensor (infra red sensor) is used to detect the movement. Sensor is used to detect the movement; if anybody opens the door forcibly the sensor will notify the microcontroller.

The transmitter and the receiver is placed beside each other and separated by an opaque material. When an intruder or object is in front of the IR, the IR ray is reflected back on the receiver which in turn sends a sensing voltage to the micro-controller unit.

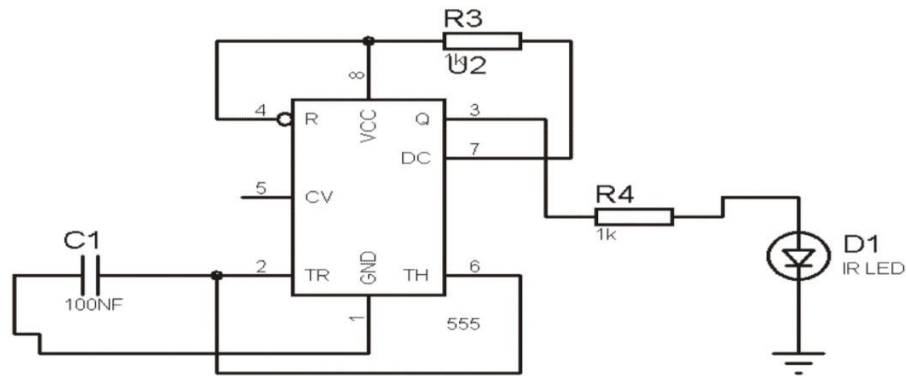

Figure 2

With the aid of the program writing, the micro-controller unit sends a command to that GSM number to call/message a saved number /numbers on the phone SIM card. The phone is connected to the USART pin of the microcontroller unit. AT command (attention command) sets is implored in the communication between the micro-controller unit and the GSM phone.

This device is highly efficient and consumes low power and portable which makes it easy to be conditioned to design changes

3.6 Codes Used In Testing:

Here are some of the tasks that can be done using AT commands with a GSM/GPRS modem or mobile phone:

1. Get basic information about the mobile phone or GSM/GPRS modem. For example, name of manufacturer (AT+CGMI), model number (AT+CGMM), IMEI number (International Mobile Equipment Identity) (AT+CGSN) and software version (AT+CGMR).
2. Get basic information about the subscriber. For example, MSISDN (AT+CNUM) and IMSI number (International Mobile Subscriber Identity) (AT+CIMI).
3. Get the current status of the mobile phone or GSM/GPRS modem. For example, mobile phone activity status (AT+CPAS), mobile network registration status (AT+CREG), radio signal strength (AT+CSQ), battery charge level and battery charging status (AT+CBC).
4. Establish a data connection or voice connection to a remote modem (ATD, ATA, etc)
5. Send and receive fax (ATD, ATA, AT+F*).
6. Send (AT+CMGS, AT+CMSS), read (AT+CMGR, AT+CMGL), write (AT+CMGW) or delete (AT+CMGD) SMS messages and obtain notifications of newly received SMS messages (AT+CNMI).Read (AT+CPBR), write (AT+CPBW) or search (AT+CPBF) phonebook entries.

4. CONCLUSION AND RECOMMENDATION

The proposed system characteristics involve remote controlling of appliances, intrusion detection, system security and auto-configuration such that system automatically adjusts the system settings on running hardware support check. The system has useful features such as displaying of battery level, charging status and signal strength of the mobile thus making system reliable.

The general operation of this work and its performance is dependent on the user who is prone to human error such as pouring of liquid plug into a higher voltage source etc.

This work can be used as a reference or as a base for realizing a scheme for monitoring other sources of insecurity. Since the performance of the work after test met the design specifications, the work thus have a very great implications considering the amount of time and resources it will save.

REFERENCES

- [1] Alkar, A. Z., & Buhur, U. (2005). An Internet Based Wireless Home Automation System for Multifunctional Devices. *IEEE Consumer Electronics*, 51 (4), 1169-1174. Retrieved February 14, 2013 from http://www.thaiee.i.com/embedded/pdf/Automation/2002_2.pdf.
- [2] Ciubotaru-Petrescu, B., Ch iciudean, D., Cioarga, R., & Stanescu, D. (2006). Wireless Solutions for Telemetry in Civil Equipment and Infrastructure Monitoring. 3rd Romanian-Hungarian Joint Symposium on Applied Computational Intelligence (SACI). Retrieved December 25, 2012 from <http://www.bmf.hu/conferences/saci2006/Ciubotaru.pdf>.
- [3] Conte, G., & Scaradozzi, D. (2003). Viewing home automation systems as multiple agents systems. *RoboCUP2003*, Padova, Italy. Retrieved January 15, 2013 from http://www.robosiri.it/ROBOCUP_2003/ROBOCUP-SITOSIRI/articles/pdf/Conte.pdf.
- [4] Delgado, A. R., Pic king, R., & Grout, V. (2006) Remote-controlled home automation systems with different network technologies. *Proceedings of the 6th International Network Conference (INC 2006)*, University of Plymouth. (pp.357-366). Retrieved January 20, 2013 from <http://www.newi.ac.uk/groutv/papers/p5.pdf>.
- [5] Jawarkar, N. P., Ahmed, V., Ladhake, S. A. & Thakare, R. D. (2008). Micro-controller based Remote Monitoring using Mobile through Spoken Commands. *Journal of Networks*, 3(2), 58-63. Retrieved February 12, 2013 from <http://www.academypublisher.com/jnw/vol03/no02/jnw03025863.pdf>.
- [6] Murthy, M. V. R. (2008). Mobile based primary health care system for rural India. *W3C workshop on Role of Mobile Technologies in Fostering Social Development*, Jun 2008 .
- [7] Potamitis, I., Georgila , K., Fa kotakis, N., & Kokkinakis, G. (2003). An integrated system for smart-home control of appliances based on remote speech interaction. *EUROSPEECH 2003*, 8th European Conference on Speech Communication and Technology, pp. 2197-2200, Geneva, Switzerland, Retrieved February 4, 2013 from <http://www.wcl.ee.upatras.gr/ai/papers/potamitis14.pdf>.